

MLT/MLT-X 840/1040/961

Agricultural & agro-industrial telehandlers



**Silent
FORCE**

MANITOU
HANDLING YOUR WORLD

Handling your world

Founded over 60 years ago by the Braud family, the Manitou Group now operates worldwide. A world-leader in all-terrain material handling, the Group designs, manufactures, distributes and services equipment for construction, agriculture and industries.

The Group's product ranges include: all-terrain fixed, rotating and heavy-load telehandlers; all-terrain, semi-industrial and industrial mast forklift trucks; wheel or track skid-steer loaders; articulate loaders; access platforms; truck-mounted forklifts; warehousing equipment; and attachments.

Through its iconic brands - Manitou, Gehl and Mustang - and its worldwide network of 1,500 dealers, the Group offers the best solutions to create optimum value for its customers.

Headquartered in France, the Group registered a revenue in 2017 of 1.600 billion euros in 140 countries and employs 3,900 people, all strongly focused on satisfying customers.

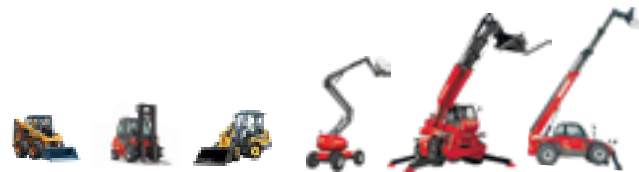

1958

Marcel Braud conceives the idea of the Manitou truck.

1972

The Group enters foreign markets.

Sales partnership agreement signed with Toyota for exclusive distribution of Toyota industrial forklift trucks in France.

1981

Launch of first Manitou telehandler.

1984

Manitou enters the stock exchange.

1993

The first MRT rotating telehandlers are sold.

1995

Launch of the first range of access platforms.

1996

ISO 9001 certification obtained.

1998

Marcel Braud becomes Chairman of the Supervisory Board.

2006

Manitou passes the 1 billion euros sales milestone.

2007

Manitou opens an international logistics centre spanning 22,000 m².

3 brands
distributed by
1,500 dealers
in 140 countries

MANITOU | **GEHL** | **MUSTANG**

- 21 subsidiaries
- 11 production facilities
- 3,900 employees worldwide
- 64% of the share capital held by the founding families
- 78% of revenue comes from foreign markets
- 1.600 billion euros of turnover in 2017

2008

Takeover of the American company Gehl.

2009

Change of management - return to a Board of Directors.

2010

Launch of Gehl and Mustang articulated loaders.

2012

Crossover agreement signed with Yanmar for the manufacture and distribution of mini-excavators.

2013

Consolidation of Yanmar partnership as Yanmar becomes a Group shareholder with 6.26% of the capital.

2014

January: Michel Denis is appointed President and CEO.
April: A new roadmap is drawn up focusing on the three divisions, including one for services.

2015

Manitou celebrates the sale of its 500,000th machine worldwide.

500 000

2016

Launch of the new MLT range, NewAg.

NEWAG

2017

Inauguration of the new entity. Manitou Equipment India, specialising in compact loaders and backhoe loaders.





SUMMARY

Comfort

Manitou ergonomics	10
Panoramic visibility	12

Performance

2 transmissions for all needs	16
Engine and cooling performance	20
Intelligent Hydraulics	21

Cost-efficiency

Reliability and cost-efficiency	24
Easy maintenance	26

Versatility

Selection of Manitou attachments	30
Select your models	32
Selection of options	35

Manitou at your service

Manitou Services	38
A connected machine	40
REDUCE program	42

General features

	ENGINES (HP)	TRANSMISSION	GEARBOX*	TYPE OF PUMP	FLOW (L)
MLT 840-115 PS+	115	Torque converter	M-Shift® with lock-up	LSU variable flow pump (load sensing ultra)	150 L
MLT 840-145 PS+	141	Torque converter	M-Shift® with lock-up	LSU variable flow pump (load sensing ultra)	200 L
MLT 1040-145 PS+	141	Torque converter	M-Shift® with lock-up	LSU variable flow pump (load sensing ultra)	200 L
MLT 1040-145 PS+ L	141	Torque converter	M-Shift® with lock-up	LSU variable flow pump (load sensing ultra)	200 L
MLT-X 840-140 PS+	137	Torque converter	M-Shift® with lock-up	LSU variable flow pump (load sensing ultra)	200 L
MLT-X 1040-140 PS+ L	137	Torque converter	M-Shift® with lock-up	LSU variable flow pump (load sensing ultra)	200 L
MLT / MLT-X 961-145 V + L	141	CVT M-Vario Plus	--	LSU variable flow pump (load sensing ultra)	200 L





max. height
9.60m

**Up to
6 tons**

max. Hydraulic
Flow
200l/m

noise level
74
DB(A)



DESIGNED FOR COMFORT

There's just one step from comfort to productivity. That's why our telehandlers bring you an optimal ergonomic level and all the features you need to concentrate fully on your activity.







MANITOU ERGONOMICS TO BOOST YOUR PRODUCTIVITY

noise level
74
DB(A)*

Silent
FORCE
THE QUIETEST
CAB ON THE
MARKET

Soundproof cab

Noise is the number one fatigue factor for Ag machinery drivers. The soundproof cab of MLT 840/1040/961 therefore directly improves your daily productivity.

Safe cab

The cab in the MLT 840/1040/961 is ROPS and FOPS level 2 compliant. It can withstand rolling over and falling heavy objects. You will be protected throughout your time using the machine.

* tested following NF EN 12053



Easy-access cab

The access to the driving station has been entirely redesigned. This model offers cab access via a proper set of steps. The non-slip "Easy-Step" and large handles on the cab frame make it even easier to climb up and down.





Comfort Steering System

CSS (optional)

World premiere patented by Manitou: the **CSS is the first intelligent steering system on a 4-wheel drive telescopic loader**, based on machine speed & boom angle. You can now achieve a complete rotation of the wheels in only 1 steering wheel turn instead of 4!

More productivity: +12% in hourly productivity on loading applications.

More comfort: -37% in wheel turns/hour and consequently decreases arm & shoulder fatigue for the driver.

More efficiency: enhances maneuverability to a level never reached before.

More safety: monitors in real time the steering behavior to maximize the stability of the machine (based on machine speed & boom angle).



A new generation of boom suspension*

The **Active Comfort Ride Control** (Active CRC) system absorbs the unwanted movements of the boom when you drive with or without a load.

The components are put under less strain, your load is protected and driver comfort is ensured.

Our "Active CRC" system operates regardless of the angle of the boom and is automatically activated when driving over 4 kph. At lower speeds, the feature is deactivated to put the priority on movement precision for easier load handling.

* Standard on Elite, optional on Premium & Classic finishing level



PANORAMIC VISIBILITY

With a large glass surface (roof and front windshield) as well as a high seating position, the MLT 840/1040/961 offer 360° visibility, ensuring the safety of both yourself and the people around you.

Panoramic interior mirror

Fitted as standard, the panoramic mirror allows you to observe your work environment effectively, thus reducing your movements in the cab.



Electric mirror with de-icing*

Activated by a control inside the cab, the external mirror is easily adjustable and enables rapid use, even in winter.

*Standard on Elite, optional on Premium & Classic finishing level.





Optimal lighting*

Work at night as if it were broad daylight, thanks to the **LED +** package as standard on the Elite version.

This package contains 4 additional lights:

- 1 at the left rear side of the cab
- 1 at the rear of the machine, above the towing hitch
- 2 at the front of the machine, on the right hand side

*Standard on Elite, optional on Premium & Classic finishing level.



Augmented visibility (optional)

Get rid of stressful blind spots to work faster and safer with the **Safe View camera pack** option. 2 Cameras at the rear and on the right hand side of the machine provide augmented day & night visibility. This option also contributes to decrease operator back/neck fatigue thanks to the in-cab display. To help you concentrate on your activity, the rear camera is automatically activated on in-cab display when the FNR is put in Reverse position. Both camera are compliant with high pressure water jet cleaning (IP69K).



SCANIA

1725 LT

CA-212-WH

MANITOU



DESIGNED FOR PERFORMANCE

Because efficiency is one of your top priorities, our agricultural and agro-industrial telehandlers offer you an unmatched level of performance to boost your productivity.



2 TRANSMISSIONS TO MEET ALL YOUR NEEDS

Goes **anywhere**

You will have no difficulty working in any conditions and on any type of surface, thanks to the following features:

- **Frame levelling** available in standard on MLT 1040 L & 961
- Agricultural profile tyres (optional semi-industrial tyres)
- High ground clearance (up to 45 cm)
- Excellent pulling force
- 4 wheel-drive and steering
- Oscillating rear axle

The MLT 840 and 1040 also come with a limited slip differential (45%) on the front and rear axles, for easy navigation on difficult terrains (optional on MLT 961).





M-Shift transmission



Torque converter lock-up function

(Torque-lock)
(MLT 840/1040)

This function, fitted as standard, locks the torque converter and drives the transmission system directly over 23 kph in fourth gear and 38 kph in fifth. This system improves the efficiency of your machine, significantly increases its traction force and reduces fuel consumption.



A torque converter to release the full power (MLT 840/1040)

This transmission increases the traction force of the machine for optimal handling of all your intensive agricultural loads. Very easy to use thanks to the **M-shift gearbox** with five speeds, it enables smooth gear changes in all situations:

- the automatic mode selects the right gear depending on the speed, automatically determining the optimal gear.
- the manual mode controls gear changes and optimizes fuel consumption, using the + and – buttons on the JSM® (Joystick Switch and Move).
- the road mode releases all the engine's potential until 40 kph.
- the handling mode associated with the inching function allows you to handle loads with the utmost precision.

A Continuous Variable Transmission to provide the best traction to precision ratio (MLT 961)

Get up to 40 kph without any gear change with the **M-Vario Plus transmission!**

This continuous variable transmission (CVT) consists of 2 hydraulic motors powered by a hydraulic pump.

At low speed, the 2 motors are active.

The tractive power is therefore comparable to that of a torque converter transmission.

At high speed, only 1 motor is active.

The maximum speed is reached with no loss of energy so that a high tractive power is retained. Fuel consumption is optimized and the sound level generated caused by the transmission is reduced.

The M-Vario Plus combines the best of precision and performance.

- **Speed control:** Adjust your maximum travel speed to adapt to your needs (comfort, safety...)
- **Standard/handling modes:** Choose the mode that best suits you and your task. The handling mode is very progressive and suitable for loading. The standard mode is a lot more dynamic and is recommended for all other tasks.
- **"Working mode" (SET):** Simplify your life by storing travel and engine speed for use with a sweeper, silage defacer...



M-vario Plus transmission



Inching function (MLT 961)

For precise and flexible handling, the dedicated inching pedal allows you to slowly lift your loads whilst keeping your engine running at a high speed for fast hydraulic movements. Wheel traction is maintained and you save significant movement speed.



Up to +40% lifting capacity increase with **frame levelling** (MLT 1040L/961)

Thanks to the +/- 7° frame levelling, you keep the load in horizontal position on all terrains. It drastically improve the machine lifting capacity at max. height, increasing your productivity. Easy to use, the frame levelling command is integrated on the JSM®, directly at your finger tips.



A choice of 4 steering modes

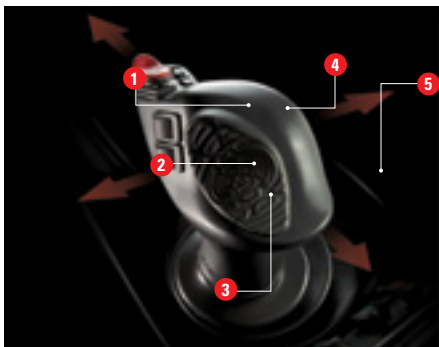
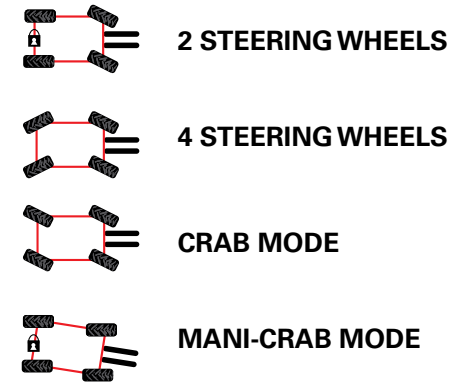

Manitou works hard to make your job easier

Control all the hydraulic functions with just one hand, using the patented JSM® joystick: you can keep one hand on the steering wheel at all times so you can do your work safely.

- 1** FNR (Front Neutral Reverse) switch
- 2** Hydraulic attachment line
- 3** Telescope: retraction and extension
- 4** Buttons + and - : changing gear



- Forward:** boom lowering
- Backward:** boom lifting
- Left:** attachment crowding
- Right:** attachment dumping

ENGINE AND COOLING PERFORMANCE

An engine block that meets your expectations

Depending on your country's engine standards, 2 types of engine are available to you, both dedicated to demanding agricultural uses.

EUROPE/NORTH AMERICA :
John Deere / 141 hp / 4.5L / 4-cylinder / Stage IV/Tier 4 Final

A complete range of exhaust treatment systems is used to meet the normative environmental requirements of the machine:

- DOC (Diesel Oxidation Catalyst)
- DEF (Diesel Exhaust Fluid) + SCR (Selective Catalytic Reduction)
- EGR (Exhaust Gas Recycling)

REST OF THE WORLD:
John Deere / 137 or 141 hp / 4.5L / 4-cylinder / Stage 3A/Tier 3

The PSD air filter and integrated pre-filter ensure a longer service life for your machine.



Time & fuel saving



Optimal cooling adapted to the agricultural environment

The fan is regulated electronically: the fan speed is controlled automatically according to the temperature of the:

- engine oil
- transmission oil
- hydraulic oil
- intercooler

This therefore reduces fuel consumption significantly.

The radiator's automatic dust removal system inverts the air flow every 3 minutes, regardless of the engine speed. Cooling is always optimal, especially in dusty environments, in the presence of straw, paper, etc. This system minimises maintenance and optimises your engine's performance while saving time and fuel.

The pre-filter grid protects the radiator against particles and improves the thermal balance of the various components.





(optional) THE INTELLIGENT HYDRAULICS SYSTEM

The new Intelligent Hydraulics System developed by our engineers will help you to improve your productivity with its three features:

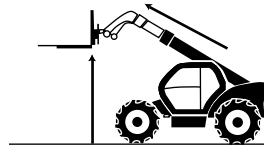

1- **"Quick Lift"**: automatically allows two simultaneous movements (raising/lowering + extension/retraction) and facilitates stocking operations.

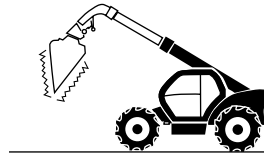

2- **"Bucket Shaker"**: quickly empties the bucket without requiring the operator to make repetitive movements. Manure will no longer stick to the bottom of the bucket.

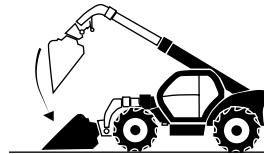

3- Automatic **"Return to Load"**: to easily return to a position (attachment and boom) pre-determined by the operator. This function is particularly useful for loading operations.



LS pump 150 or 200 l/min

The LS variable flow pump guarantees you optimal speed for all your hydraulic movements, enabling them to be performed simultaneously so that you work more efficiently.

The system also has two flow regulators, which adjust the hydraulic speed of your attachments. This allows you to optimise the opening and closing of your attachment.



DESIGNED FOR COST-EFFICIENCY

Manitou latest innovations include intelligent tools to improve performance, productivity and maintenance. Optimising your Total Cost of Ownership (TCO) is our priority: reducing work time and fuel consumption has a direct impact on your bottom line. Increasing availability of the machine with easier access to the main components facilitates maintenance. Extended maintenance intervals lowers your maintenance costs. With a connected machine, critical information is now available at your fingertips via a mobile app.





RELIABILITY AND COST EFFICIENCY

Using gravity to improve productivity

The **Regenerative Hydraulics** system makes it possible to lower the boom, regardless of engine speed, using gravitational force. Save time and fuel on every boom lowering manoeuvre.

A proven boom design for absolute reliability

The double U design boom is welded in the parts subjected to least pressure. The boom is in two sections (duplex) on the MLT 840/961 and three sections (triplex) on the MLT 1040. Its robust structure and the increased rapidity of its cycle time offer you optimal performance for intensive applications.

Controlled braking

Reinforced and watertight, the heavy duty front and rear axles integrate oil immersed brakes. Your machine's braking system is protected and stay reliable over time. You can work on demanding tasks securely, with brakes on all four wheels.

The parking brake is activated automatically via the negative brake or manually by the operator. Regardless of the situation or steepness of slope, the machine can be parked safely.





The differential lock ensures a smooth drive (MLT 840 / 1040)

The differential lock, fitted as standard, allows you to drive easily on low-grip surfaces, without impacting on your level of productivity.

Cost efficiency

Eco mode: Thanks to the Eco mode (on MLT 961), the engine speed is automatically optimized while guaranteeing high performances. Fuel consumption and sound pollution are greatly reduced.



TCO friendly (Total Cost of Ownership)

Eco Stop: (optional) It automatically shuts down the engine and associated hour meter when driver is out of the cab, based on time setting. This feature impacts up to 82% of the machine TCO (Total Cost of Ownership).

- **Machine depreciation reduction (37% of TCO in agriculture):** the Eco Stop feature stops the engine and associated hour meter. Idle regime without driver represents 30% of total hours in Ag applications.
- **Fuel consumption reduction (32% of TCO in agriculture):** the Eco Stop feature stops engine & associated idle fuel consumption.
- **Preventive maintenance reduction (13% of TCO in agriculture):** the Eco Stop decreases the preventive maintenance frequency. It also reduces the exhaust line clogging due to engine idling.

EASY MAINTENANCE

Quick and easy access to the engine

The engines of our telehandlers are mounted on the right side of the chassis, and are easy to access. It is also possible to open the lower section of the engine cover (without removing it), for more heavy maintenance.



High capacity tanks

The fuel, urea and hydraulic oil tanks are easily accessible and clearly labelled.

An anti-vandalism device provides protection from possible theft of fuel or urea. The fuel tank, with a capacity of 126 litres (MLT 840/1040) / 135l (MLT 961), is ideal for all-day use and allows you to optimise actual working time on the long run.





Centralised greasing points

The MLT 840/1040/961 are fitted as standard with central greasing points located at the rear of the machine. These greasing points are for:

- the compensating cylinder (two greasing point at the base of the cylinder)
- the lifting cylinder (two greasing point at the base of the cylinder)
- the rear axle oscillation (two greasing points)

The greasing points on the front and rear axles are also centralised, easy to access and provide you with significant time savings.

Intelligent maintenance

The display screen, located inside the cab, allows you to retrieve all the data needed for the maintenance of your machine, including the maintenance hour meter.

The item reference numbers are listed in the operator manual, making it easier for you to communicate with your Manitou dealer.





VERSATILITY FIRST AND FOREMOST

Manitou agricultural telehandlers can be configured according to your expectations and fitted with attachments created specifically for your applications.





Manitou, as a manufacturer of machines and attachments, is the best placed to guarantee you uncompromising performance and safety.

With Manitou original attachments, enjoy guaranteed site flow and total peace of mind!

Discover all our attachments on

manitou.com 



CBG MS
High capacity Agricultural Grab Bucket

- Versatile tool
- Handling of fodder, manure and agricultural bulk
- Up to a capacity of 2600 l (bucket closed).



CBG FO
Forged Grab Bucket

- Precise cutting of silage heaps
- Handling of manure
- Capacity of 1695 l (bucket closed) for an unrivalled site flow.



CBA
Agricultural Bucket

- Handling of agricultural bulk: cereals, sugar beet pulp, etc.
- Guaranteed lightness, sturdiness and performance
- 500 HB reversible bolt-on wear plate (LDR) available as option.



HBB
Big Bag Handler

- Handles one to four big bags
- Secure handling
- More efficient loading and unloading operations.



Bale Clamps and Forks

- Square, round or wrapped bales
- Safe and efficient working
- Quality of the bales preserved.



FMG
High Capacity Manure Fork

- High capacity
- Handling of straw manure
- Greater performance and flow
- Guaranteed visibility.

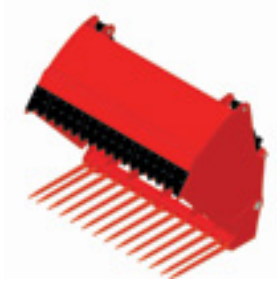

**SHG
Shear Grab**

- Perfect cutting of all silage
- Limited refermentation of feed
- Quality and nutritional value of feed preserved.

**SHB
Shear Grab Bucket**

- Perfect cutting of corn or grass silage
- Limited refermentation of feed
- Quality and nutritional value of feed preserved
- A single attachment to handle cereals, mineral supplements

**SCC
2 in 1**

- 2 in 1 : sweeper collector and side-pushing sweepe
- A competitive solution offering perfect quality of work
- Light to medium-intensity applications.

**CBR
Rehandling Bucket**

- Handling of heavy materials (max. 2100kg/m³).
- Reinforced structure for greater durability.
- Also available with 500 HB reversible bolt-on wear plate (LDR).



**BSB
Sugar Beet Bucket**

- Designed for sugar beet and other root vegetables and tubers
- Releases soil and other foreign matter.

**CGD
Shear Bucket Distributor**

- Rapid distribution of silage (or a pre-mixed preparation) to animals
- Maximum efficiency.

**CRS
Silage Facer Bucket**

- Pick up of heaped silage
- Airing of silage so that it may be consumed directly by the animals
- Clean cutting edge
- Limited refermentation.

**PFB
Tilting Fork Carriage**

- Simple handling solution
- Bolted load backrest available as option
- FEM forks provided as standard; length of forks vary depending on model.

SELECT THE MODEL THAT IS RIGHT FOR YOU

MLT 840



Transmission	C/CVT*
Engine power	hp - kW
Engine brand	-
Max. capacity	kg/lbs
Max. lifting height	m/ft
Max. outreach	m/ft
Dimensions without attachments (LxWxH)	m/ft
Hydraulics	l/min - bar gpm - psi
Unladen weight with forks	kg/lbs
Max. speed	kph/mph

MLT 840 115 PS+ / 145 PS+	MLT-X 840 140 PS+
C "M-Shift"	C "M-Shift"
115 - 86 / 141 - 104	137 / 102
JOHN DEERE	JOHN DEERE
4 000 / 9000	4 000 / 9000
7.55 / 24'11"	7.55 / 24'11"
4.45 / 14'8"	4.45 / 14'8"
5.37 x 2.39 x 2.39 17'8" x 7'1" x 7'1"	5.37 x 2.39 x 2.39 17'8" x 7'1" x 7'1"
150-270 / 200-270 39.63-3916 / 52.84-3916	200-270 52.84-3916
8410 / 18521	8410 / 18521
40 / 25	40 / 25

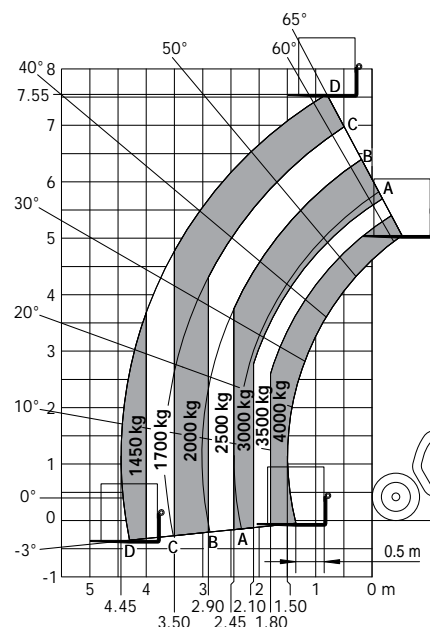

Rough terrain load chart standard EN1459 B
Machines on tyres with forks

MLT 1040



MLT 1040 145 PS+
C "M-Shift"
141 / 104
JOHN DEERE
4 000 / 9000
9.60 / 31'7"
6.55 / 21'7"
5.17 x 2.39 x 2.38 16'11" x 7'1" x 7'1"
200-270 52.84-3916
8 890 / 19578
40 / 25

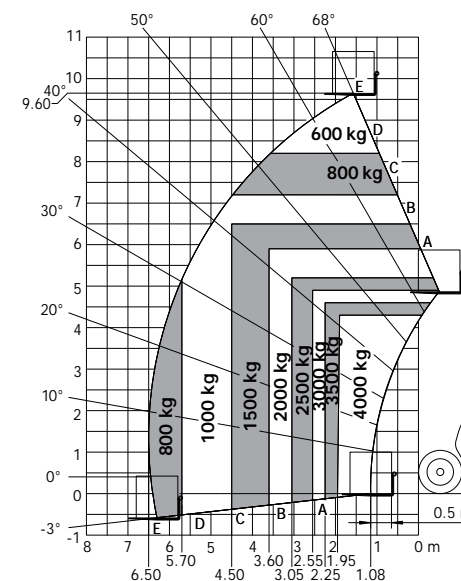

Rough terrain load chart standard EN1459 B -
Machines on tyres with forks

* C: Torque converter with M-Shift gearbox
CVT: Continuous Variable Transmission



MLT 961

MLT 1040 145 PS+ L	MLT-X 1040 140 PS+ L
C "M-Shift"	C "M-Shift"
141 /104	137 /102
JOHN DEERE	JOHN DEERE
4 000/9000	4 000/9000
9.60/31'7"	9.60/31'7"
6.55/21'7"	6.55/21'7"
5.17 x 2.39 x 2.38 16'11"x7'1"x7'1"	5.17 x 2.39 x 2.38 16'11"x7'1"x7'1"
200-270 52.84-3916	200-270 52.84-3916
9175/20227	9175/20227
40/25	40/25

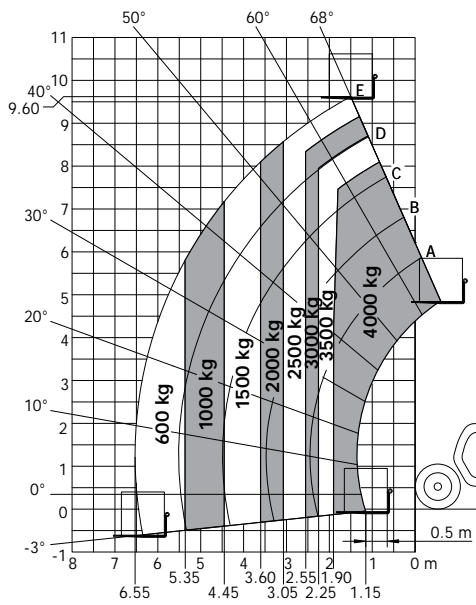

Rough terrain load chart standard EN1459 B
Machines on tyres with forks

MLT & MLT-X 961 145 V+ L
CVT "M-Vario Plus"
141 /104
JOHN DEERE
6 000/13228
9.00/29'7"
5.30/17'5"
6.10 x 2.48 x 2.53 20'x8'x8'4"
200-270 52.84-3916
11800/26015
40/25

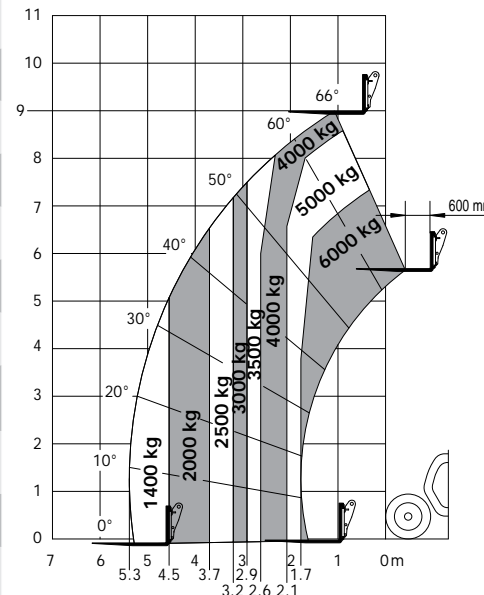

Rough terrain load chart standard EN1459 B
Machines on tyres with forks

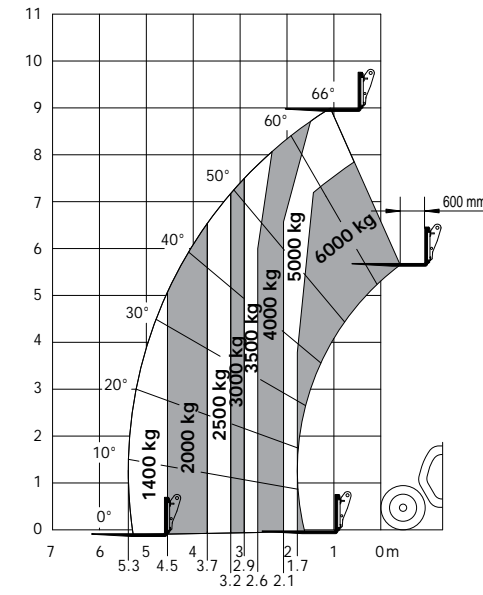

Industrial load chart standard EN1459 A
Machines on tyres with forks



	MLT 840-115 PS+			MLT 840-145 PS+			MLT 1040-145 PS+			MLT 1040-145 PS+ L			MLT-X 840-140 PS +			MLT-X 1040-140 PS+ L			MLT & MLT-X 961 145 V+ L					
General																								
Auto reversing fan	s	s	s	s	s	s	s	s	s	s	s	s	s	s	s	s	s	s	s	s	s			
Boom suspension - "Active CRC"	o	o	s	o	o	s	o	o	s	o	o	s	o	o	s	o	o	s	o	o	s	o	o	s
Hand throttle	o	o	s	o	o	s	o	o	s	o	o	s	o	o	s	o	o	s	o	o	s	s	s	s
Automatic wheel alignment	o	o	s	o	o	s	o	o	s	o	o	s	o	o	s	o	o	s	o	o	s	o	o	s
Centralized grease points	s	s	s	s	s	s	s	s	s	s	s	s	s	s	s	s	s	s	s	s	s	s	s	s
Manual rotating towing hitch	s	s	s	s	s	s	s	s	s	s	s	s	s	s	s	s	s	s	s	s	s	s	s	s
Automatic rotating towing hitch D40 or D50	o	o	o	o	o	o	o	o	o	o	o	o	o	o	o	o	o	o	o	o	o	o	o	o
Hydraulic pick-up hitch (low or high position)	o	o	o	o	o	o	o	o	o	o	o	o	o	o	o	o	o	o	o	o	o	o	o	o
Ladder hitch with module(s)	o	o	o	o	o	o	o	o	o	o	o	o	o	o	o	o	o	o	o	o	o	o	o	o
Ecostop	o	o	o	o	o	o	o	o	o	o	o	o	o	o	o	o	o	o	o	o	o	o	o	o
Comfort																								
Joystick Switch and Move (JSM) on floating & adjustable armrest	s	s	s	s	s	s	s	s	s	s	s	s	s	s	s	s	s	s	s	s	s	s	s	s
Manual air conditioning	o	s	s	o	s	s	o	s	s	o	s	s	o	s	s	o	s	s	o	s	s	o	s	s
Mechanical cloth-covered seat	s	-	-	s	-	-	s	-	-	s	-	-	s	-	-	s	-	-	s	-	-	s	-	-
Air suspension cloth-covered seat	o	s	-	o	s	-	o	s	-	o	s	-	o	s	-	o	s	-	o	s	-	o	s	-
Low frequency air suspension cloth-covered seat	o	o	s	o	o	s	o	o	s	o	o	s	o	o	s	o	o	s	o	o	s	o	o	s
Low frequency air suspension cloth-covered seat with heating & electric lumbar adjustment	o	o	o	o	o	o	o	o	o	o	o	o	o	o	o	o	o	o	o	o	o	o	o	o
CD / MP3 car radio	s	-	-	s	-	-	s	-	-	s	-	-	s	-	-	s	-	-	s	-	-	s	-	-
Bluetooth USB car radio with integrated microphone (100 W)	o	s	-	o	s	-	o	s	-	o	s	-	o	s	-	o	s	-	o	s	-	o	s	-
Bluetooth USB car radio with extra microphone (100 W)	o	o	s	o	o	s	o	o	s	o	o	s	o	o	s	o	o	s	o	o	s	o	o	s
Hydraulics																								
Easy Connect System (ECS)	s	s	s	s	s	s	s	s	s	s	s	s	s	s	s	o	s	s	s	s	s	s	s	s
Attachment hydraulic line	s	s	s	s	s	s	s	s	s	s	s	s	s	s	s	s	s	s	s	s	s	s	s	s
Regenerative hydraulics	o	s	s	o	s	s	o	s	s	o	s	s	o	s	s	o	s	s	o	s	s	o	s	s
Intelligent Hydraulics (Quick Lift, Return to Load, Bucket Shaker)	o	o	s	o	o	s	o	o	s	o	o	s	o	o	s	o	o	s	o	o	s	o	o	s
Continuous flow hydraulics	o	o	s	o	o	s	o	o	s	o	o	s	o	o	s	o	o	s	o	o	s	o	o	s
Attachment hydraulic locking	o	o	o	o	o	o	o	o	o	o	o	o	o	o	o	o	o	o	o	o	o	o	o	o
Return pipe to hydraulic oil tank	o	o	o	o	o	o	o	o	o	o	o	o	o	o	o	o	o	o	o	o	o	o	o	o
1 pair of pre-fitted double action rear hydraulic couplers	o	o	o	o	o	o	o	o	o	o	o	o	o	o	o	o	o	o	o	o	o	o	o	o
Electrovalve for 2 hydraulic functions (on boom head)	o	o	o	o	o	o	o	o	o	o	o	o	o	o	o	o	o	o	o	o	o	o	o	o
Hydraulic and/or air trailer brake	o	o	o	o	o	o	o	o	o	o	o	o	o	o	o	o	o	o	o	o	o	o	o	o
Electricity / Safety																								
Front and rear work lights on cab (x4: 2 at the front + 2 at the rear)	s	-	-	s	-	-	s	-	-	s	-	-	s	-	-	s	-	-	s	-	-	s	-	-
LED Front and rear work lights on cab (x4: 2 at the front + 2 at the rear)	-	s	s	-	s	s	-	s	s	-	s	s	-	s	s	-	s	s	-	s	s	-	s	s
LED+ (4 extra work lights)	o	o	s	o	o	s	o	o	s	o	o	s	o	o	s	o	o	s	o	o	s	o	o	s
LED work lights on boom head (on fixed part) (x2)	o	o	o	o	o	o	o	o	o	o	o	o	o	o	o	o	o	o	o	o	o	o	o	o
LED front road lights (x2)	o	o	o	o	o	o	o	o	o	o	o	o	o	o	o	o	o	o	o	o	o	o	o	o
SafeView camera pack (x2: rear + right hand side)	o	o	o	o	o	o	o	o	o	o	o	o	o	o	o	o	o	o	o	o	o	o	o	o
Rear electric plug	s	s	s	s	s	s	s	s	s	s	s	s	s	s	s	s	s	s	s	s	s	s	s	s
Pre-fitted 12V electric supply on the top of the boom (on fixed part)	o	o	o	o	o	o	o	o	o	o	o	o	o	o	o	o	o	o	o	o	o	o	o	o
Electric mirror with de-icing	o	o	s	o	o	s	o	o	s	o	o	s	o	o	s	o	o	s	o	o	s	o	o	s
Windshield protection grid	o	o	o	o	o	o	o	o	o	o	o	o	o	o	o	o	o	o	o	o	o	o	o	o
Audio warning on reverse movements	o	o	o	o	o	o	o	o	o	o	o	o	o	o	o	o	o	o	o	o	o	s	s	s



The ECS (Easy Connect System)

The **ECS (Easy Connect System)** lets you disconnect attachments without turning off the engine, making it quick and easy to change your hydraulic accessories. This saves you time, and makes changing attachments less arduous.



Suspension and comfort

The **Active CRC boom suspension system** cushions movements, enhancing your comfort and protecting boom components. **Air-conditioning** offers driving comfort in all weather conditions. The **low frequency air suspension cloth-covered seat** provides greater comfort for the operator as the vibrations are better absorbed.

Tyres



Manitou offers several kinds of agricultural or semi-industrial tyres depending on the purpose of your machine, your terrain and any specific needs you may have.



Radio

The MLT 840 / 1040 / 961 offer three types of radio depending on the level of finish chosen:

- Classic : tuner car radio (50 W)
- Premium : Bluetooth USB car radio with integrated microphone (100 W)
- Elite : Bluetooth USB car radio with extra microphone (100 W)



MANITOU AT YOUR SERVICE

To enable you to benefit from an operational telehandler all year long, Manitou offers a wide range of products and services that are suited to all your needs.







Expertise and service on a daily basis

Your Manitou dealership guarantees a complete range of services at all stages of your machine's life.

1,500 dealers at your service

The Manitou network operates in more than 140 countries. In total, there are more than 8,000 expert technicians, specially trained in Manitou technology, who are at your service to assist with everything from purchasing to after-sales.



- **Dealership network**
 A network of experts at your service, whatever your activity (agriculture, construction, industry).
- **Maintenance contracts**
 3 levels of contract, tailored to your needs: Initial, Advanced, Excellence. Let your dealer take care of your equipment maintenance.
- **Financing**
 Rent or buy? Whatever your business, simplify your investment with Manitou Finance financing or rental solutions.
- **Warranty extension**
 With Maniplus, you can extend the cover of your Manitou for up to 5 years. Use your equipment with peace of mind.
- **The connected solution**
 Easy Manager is a simple and flexible tool for managing, optimising and securing the operational monitoring of your machines.
- **Second-hand**
 Are you looking for second-hand equipment? The Manitou network can help you. Visit your dealer or manitou.com, the reference site for second-hand Manitou equipment.
- **Original spare parts**
 With more than 70,000 products available, your Manitou dealer provides expertise and service on a daily basis!

A CONNECTED MACHINE

Easy MANAGER is a simple and flexible tool to maximize the operational monitoring of your equipment. The option is available at the time of order or an after-sales basis.

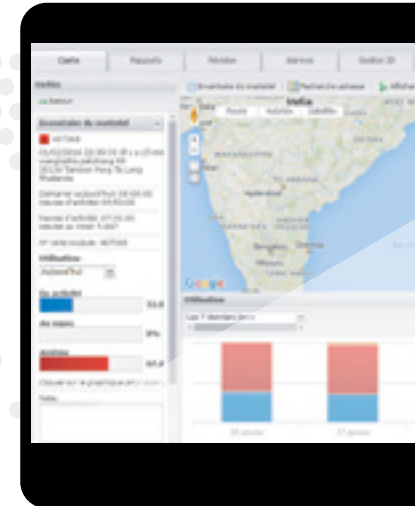



Management

See the machine's geographical location and use in real time.
Increase your machine's availability by allowing your dealer to carry out remote diagnostics.
Control your budget by ensuring optimum machine maintenance. Maximize the machine's resale value.

Optimization

Trust the maintenance of your equipment to your dealer, who can access the machine usage data and arrange maintenance operations to suit you.
Analyze your equipment's performances using the dashboard and activity reports to optimize its use and fuel consumption.

Security

Protect your equipment against theft and fraudulent use by setting up warnings.
Control access to your equipment to authenticate users and ensure their safety.

REDUCE

The Manitou Group's vision

The REDUCE approach aims to improve our machine users' quality of life at work to enhance productivity and protect the environment. This calls for transparency of fuel consumption data, reduced emissions, raising awareness of the total cost of ownership(TCO), and greater emphasis on the health and safety of users.

Do you really know the total cost of ownership of your equipment?

TREDUCE TCO (Total Cost of Ownership) gives you detailed information about the breakdown of cost items for your machine and helps you to optimise the profitability of your production tool.



Calculate your TCO at
tco.manitou.com

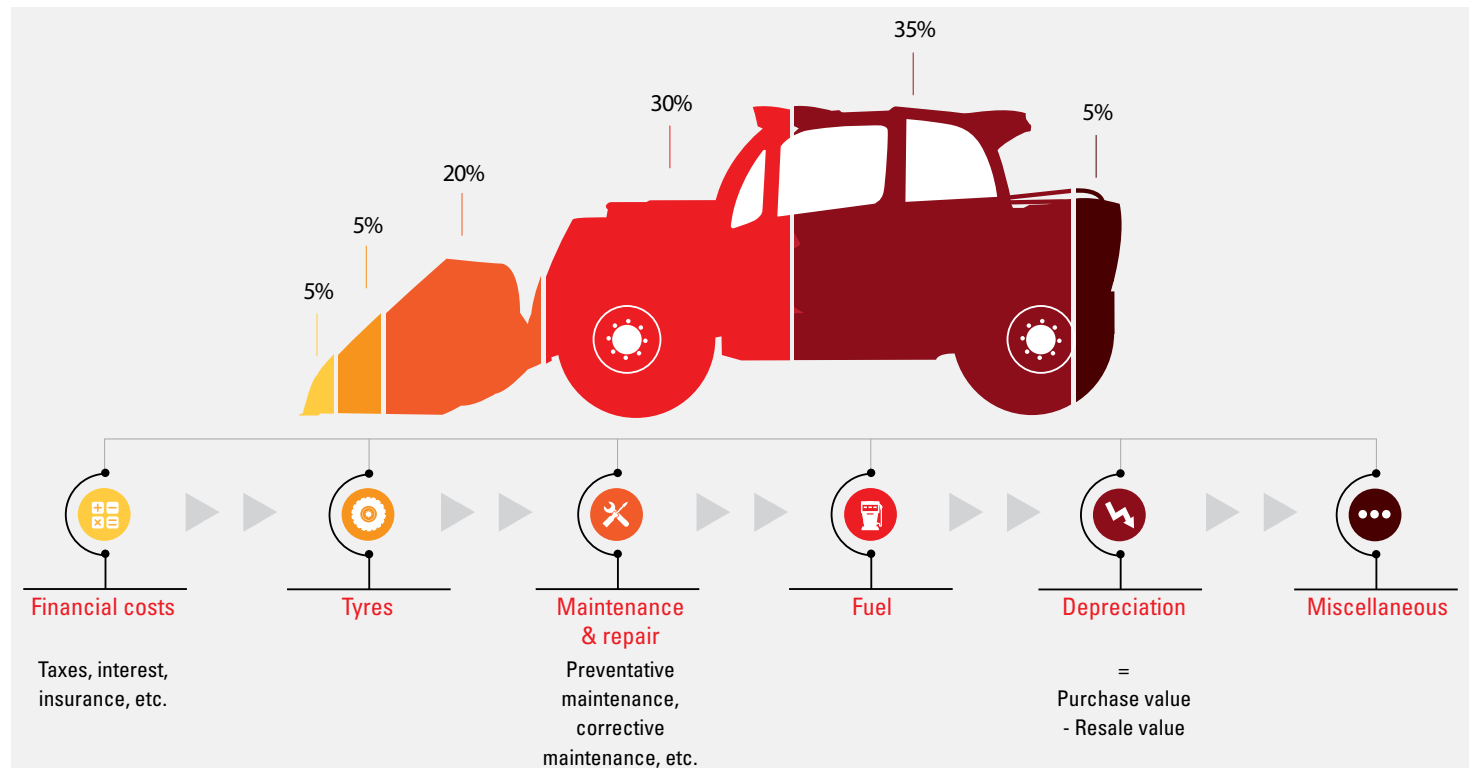

TCO what is it?

The TCO is the total cost of ownership of an asset, more commonly known as the running cost. This indicator considers both fixed costs such as acquisition, interest, rent, residual value, etc., and variable costs linked to the use of your machine, such as such as maintenance, user training, etc.



Do you know the fuel consumption of your machine?

Unlike the car sector, the material handling sector has no standardised testing scheme. We have therefore implemented a transparent internal protocol to inform you of the fuel consumption measurements of our machines. In order to provide you with reliable, clear and transparent information, this data has been verified by a recognised body.

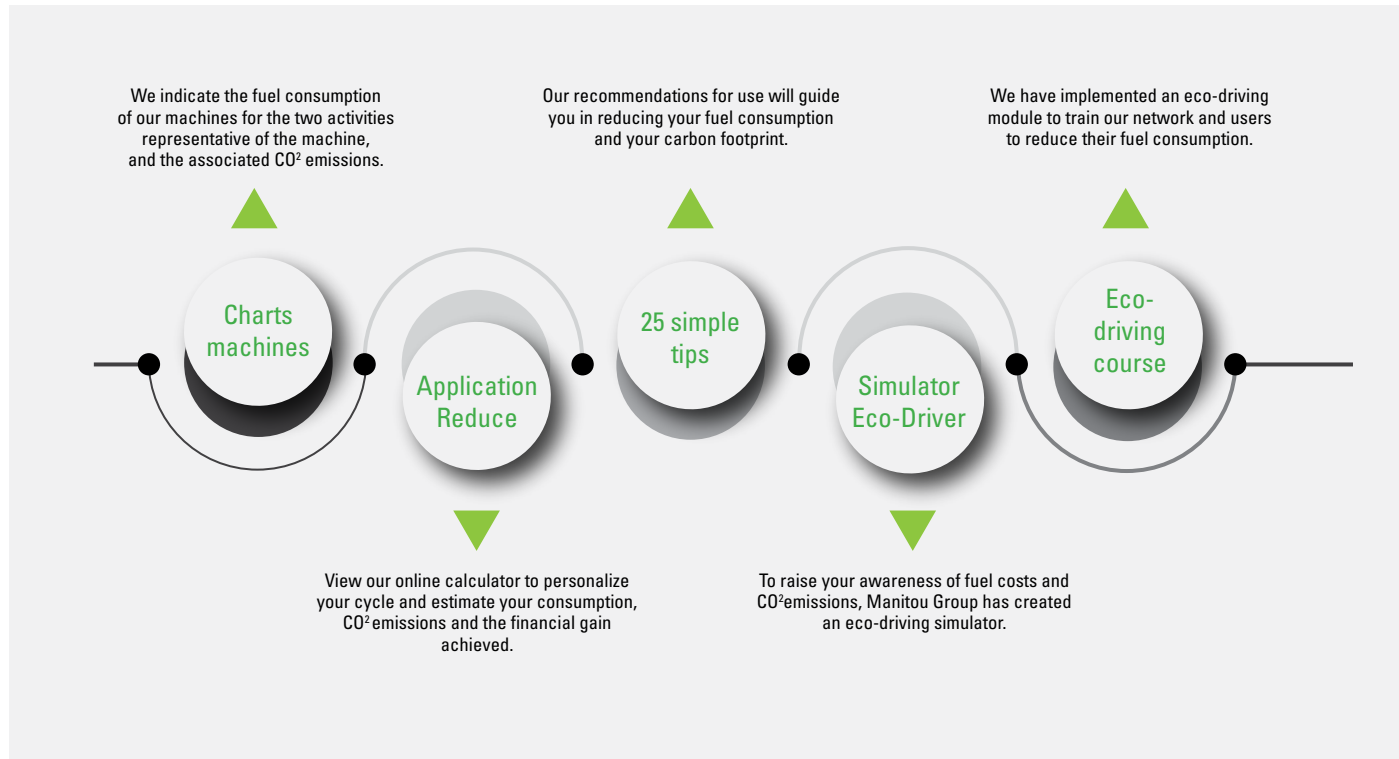

The REDUCE Fuel Eco-Program informs you with complete transparency of the fuel consumption and CO₂ emissions of our MLT and MT machines and platforms.



Calculate your fuel consumption at reduce.manitou.com

Your dealer:



 **MANITOU**
HANDLING YOUR WORLD

Head office
B.P. 249 - 430 rue de l'Aubinière - 44158 Ancenis Cedex - France
Tel.: 00 33 (0)2 40 09 10 11 - Fax: 00 33 (0)2 40 09 10 97



This brochure describes versions and configuration options for Manitou products which may be fitted with different equipment. The equipment described in this brochure may be standard, optional or not available depending on version. Manitou reserves the right to change the specifications shown and described at any time and without prior warning. The manufacturer is not liable for the specifications given. For more information, contact your Manitou dealer. Non-contractual document. Product descriptions may differ from actual products. List of specifications is not comprehensive. The logos and visual identity of the company are the property of Manitou and may not be used without authorisation. All rights reserved. The photos and diagrams contained in this brochure are provided for consultation and information only. MANITOU BF SA - Limited company with board of directors - Share capital: 39,547,824 euros - 857 802 508 RCS Nantes